



SBC28DC

Single board computer for 28 pin DIP PICs

Table of Contents

1 Introduction.....	2
2 Features.....	4
3 Expansion Connectors.....	5
3.1 Daughter Board Connectors.....	5
3.2 Frontend Connectors.....	6
3.3 Connecting IDC connectors to the Frontend Connector.....	7
3.4 Expansion boards.....	7
4 Interfaces.....	8
4.1 Micro Match connector with I2C and SPI signals.....	8
4.2 RS232.....	8
5 Configuration.....	9
5.1 Power via D-Sub connector.....	9
6 Specifications.....	9
6.1 Absolute Maximum Ratings.....	9
6.2 Electrical Characteristics.....	9
6.3 D.C. Characteristics of user I/O pins on Daughter Board connector.....	10
7 Dimensions.....	11
8 Schematics and PCB layout.....	12

1 Introduction

The following documentation is for the SBC28DC Revision 1, which is marked on the PCB as SBC28DC Rev1!

The SBC28DC is a single board computer for 28 pin PIC microcontrollers. It has a RS232 serial interface that is available via a standard 9 pin D-Sub, male connector.

This board has been optimized for the following 28 pin DIP PIC chips:

- PIC18F242, PIC18F252, PIC18F248, PIC18F258
- PIC18F2320, PIC18F2410, PIC18F2680 (CAN BUS), PIC18F2550 (USB)
- PIC16F870, PIC16F873(A), PIC16F876(A)
- PIC16C63, PIC16C66, PIC16C73(A), PIC16F73, PIC16C76, PIC16F76

This is only because the above mentioned chips have internal USARTs, which are connected to the serial drivers on this board. It can however also be used with **most other 28 pin DIP PIC chips**, as long as their power, reset(MCLR) and oscillator pins are situated in the same place as the chips listed above. The only difference is that if a USART is required, it will have to be done with software on the PIC chip. Examples of other PIC chips that can be used are:

- PIC16F872
- PIC16C62(A), PIC16C72
- Many more PIC chips that match the above mentioned criteria!

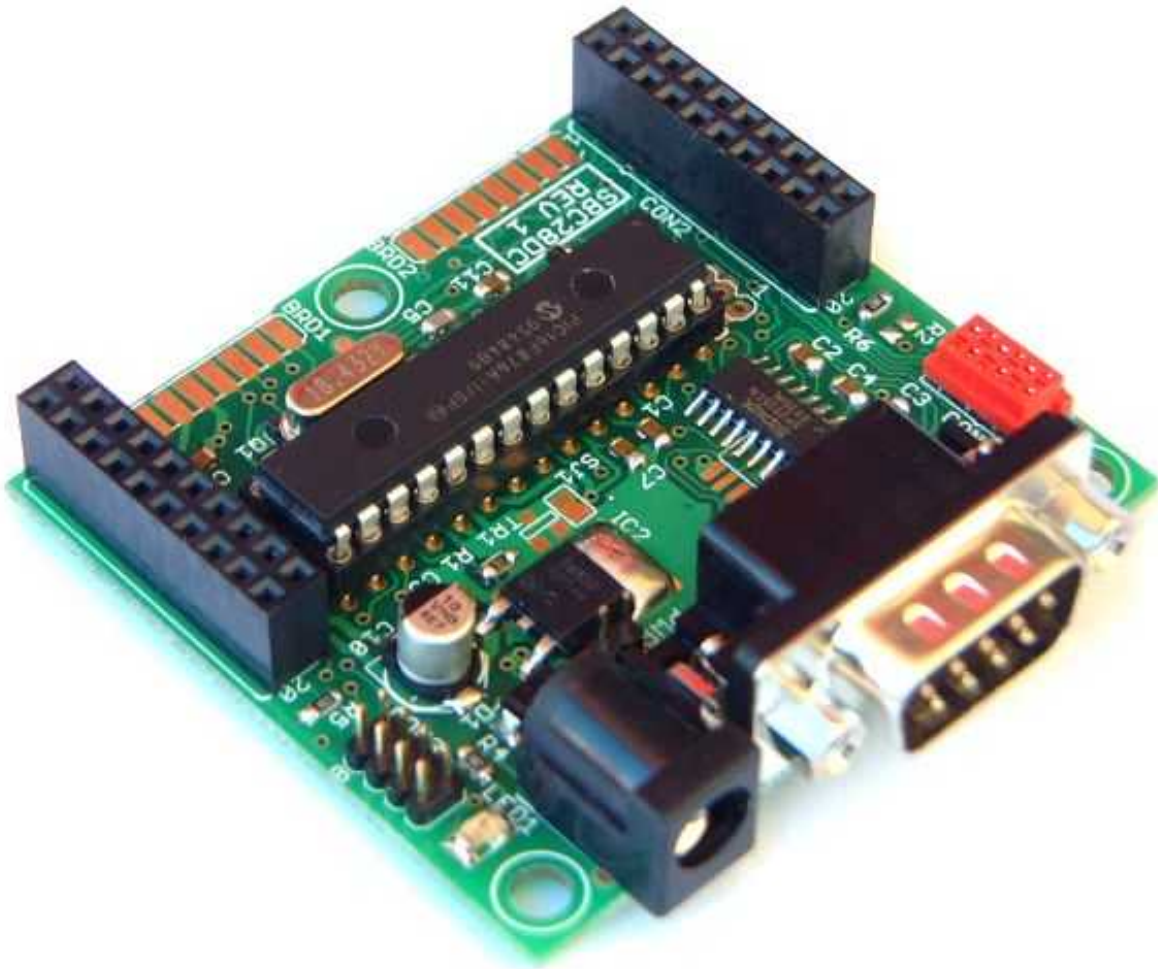

Figure 1

2 Features

- 22 I/O ports when using common PIC chips, for example the PIC16F876A or PIC18F252.
- Is part of our MicroX product range, and has a **Frontend connector** and **Compact Daughter board connector** for expansion. Any of our Daughter or Compact Daughter boards can be plugged into it. For example, a prototype Daughter board can be plugged into it for the user to do prototyping. For details on our MicroX range see www.modtronix.com/microx.
- Compact size of 58mm x 54mm. For details see www.modtronix.com/microx/dimensions.
- Assembled with High Quality, Industrial Temperature components - electrolytic capacitors used are extra long lifetime rated!
- Diode protected 2.1mm power connector for a standard DC transformer.
- Wide operating voltage range from 7 to 30V. It is recommended to use a 7.5V or 9V DC power supply.
- On board 15kV ESD protected RS232 interface. Assembled with industrial temperature range interface driver chip.
- Standard 9 pin, D-Sub male connector with RS232 signals, ground and external power.
- The power pin (pin 9) on the D-Sub connector can be connected to the boards unregulated power supply (the input of the 2.1mm power connector) via a jumper. This can be used to obtain power for this board. When used, no power has to be supplied via the 2.1mm power connector. It will obtain it's power via the D-Sub connector.
- Power LED to indicate when device is powered.
- Micro Match socket with Power, I²C and SPI signals. The Micro Match connector can be used to daisy chain multiple I²C devices together.
- Has a standard Modtronix ICSP (In Circuit Serial Programming) connector for programming the on board PIC chip - CPU can be programmed in circuit. For details see <http://www.modtronix.com/picboards/prog>

3 Expansion Connectors

3.1 Daughter Board Connectors

The SBC28DC's Daughter Board connectors can be used as an expansion port to add additional functionality. It contains all free CPU port pins, power, I2C, SPI, RS232 signal,..... For the location of the Daughter Board connectors, see the *Dimensions* chapter of this document. The Daughter Board connectors port pins are mapped to the following signals:

<i>CON2 Daughter Board Connector</i>		<i>CON1 Daughter Board Connector</i>	
<i>Daughter Board Port Pin</i>	<i>Signal</i>	<i>Daughter Board Port Pin</i>	<i>Signal</i>
T0	Routed to T0 pin of Frontend Connector	T4	Routed to T4 pin of Frontend Connector
T1	Routed to T1 pin of Frontend Connector	T5	Routed to T5 pin of Frontend Connector
T2	Routed to T2 pin of Frontend Connector	T6	Routed to T6 pin of Frontend Connector
T3	Routed to T3 pin of Frontend Connector	T7	Routed to T7 pin of Frontend Connector
SIG0	RS232 receive signal at RS232 signal levels!	GND	Ground
SIG1	RS232 transmit signal at RS232 signal levels!	+5V	Regulated 0.5A 5V supply
B0	PIC pin RB0	VIN	Unregulated input voltage
B1	PIC pin RB1	CLR#	PIC pin /MCLR
B2	PIC pin RB2 – also used for CAN TXD ⁽⁴⁾	A0	PIC pin RA0
B3	PIC pin RB3 – also used for CAN RXD ⁽⁴⁾	A1	PIC pin RA1
B4	PIC pin RB4	A2	PIC pin RA2
B5	PIC pin RB5	A3	PIC pin RA3
B6	PIC pin RB6 – also used for ICP ⁽¹⁾	A4	PIC pin RA4
B7	PIC pin RB7 – also used for ICP ⁽¹⁾	A5	PIC pin RA5
C4	PIC pin RC4 – port pin assigned for I ² C ⁽²⁾	C0	PIC pin RC0
C5	PIC pin RC5	C1	PIC pin RC1
C6	PIC pin RC6 – also used for RS232/RS485 RX ⁽³⁾	C2	PIC pin RC2
C7	PIC pin RC7 – also used for RS232/RS485 RX ⁽³⁾	C3	PIC pin RC3 – port pin assigned for I ² C ⁽²⁾
D6	N.C. - not connected	D0	N.C. - not connected
D7	N.C. - not connected	D1	N.C. - not connected

(1) Port Pins B6 and B7 are also used for in circuit programming, if the board is programmed in circuit! If they are used, and the board should still be in circuit programmable, make sure their impedance is greater than a 1000 ohms!

(2) Port Pins C3 and C4 are assigned to be used as I²C pins. When no I²C devices are used, these ports can be used as general purpose I/O pins.

(3) These pins are also used for RS232 transmit and received! If RS232 interface is not used, these ports can be used as general purpose I/O pins.

(4) These pins are also used for CAN BUS transmit and receive signals when the CAN bus is used. If the CAN bus is not used, these pins can be used as general purpose I/O pins.

3.2 Frontend Connectors

The SBC28DC's Frontend connectors can be used as an expansion port to add additional functionality. It contains all free CPU port pins, power, I2C, SPI, RS232 signal,..... Most important pins have been placed on BRD1 connector, so a single IDC connector can be connected to it, and it's signals will be available via a ribbon cable. For the location of the Frontend connectors, see the *Dimensions* chapter of this document. The Frontend connectors port pins are mapped to the following signals:

<i>BRD2 Frontend Connector</i>		<i>BRD1 Frontend Connector</i>	
<i>Frontend Port Pin</i>	<i>Signal</i>	<i>Frontend Port Pin</i>	<i>Signal</i>
T0	Routed to T0 pin of Daughter Board	T4	Routed to T4 pin of Daughter Board
T1	Routed to T1 pin of Daughter Board	T5	Routed to T5 pin of Daughter Board
T2	Routed to T2 pin of Daughter Board	T6	Routed to T6 pin of Daughter Board
T3	Routed to T3 pin of Daughter Board	T7	Routed to T7 pin of Daughter Board
SIG0	RS232 receive signal – at RS232 signal levels!	GND	Ground
SIG1	RS232 transmit signal – at RS232 signal levels!	+5V	Regulated 0.5A 5V supply
B0	PIC pin RB0	VIN	Unregulated input voltage
B1	PIC pin RB1	CLR#	PIC pin /MCLR
B2	PIC pin RB2 – also used for CAN TXD ⁽⁴⁾	A0	PIC pin RA0
B3	PIC pin RB3 – also used for CAN RXD ⁽⁴⁾	A1	PIC pin RA1
B4	PIC pin RB4	A2	PIC pin RA2
B5	PIC pin RB5	A3	PIC pin RA3
B6	PIC pin RB6 – also used for ICP ⁽¹⁾	C2	PIC pin RC2
B7	PIC pin RB7 – also used for ICP ⁽¹⁾	C3	PIC pin RC3 – port pin assigned for I ² C ⁽²⁾
A4	PIC pin RA4	C4	PIC pin RC4 – port pin assigned for I ² C ⁽²⁾
A5	PIC pin RA5	C5	PIC pin RC5

- (1) Port Pins B6 and B7 are also used for in circuit programming, if the board is programmed in circuit! If they are used, and the board should still be in circuit programmable, make sure their impedance is greater than a 1000 ohms!
- (2) Port Pins C3 and C4 are assigned to be used as I²C pins. When no I²C devices are used, these ports can be used as general purpose I/O pins.
- (3) These pins are also used for CAN BUS transmit and receive signals when the CAN bus is used. If the CAN bus is not used, these pins can be used as general purpose I/O pins.

Figure 2 shows the location of the Frontend Connectors on the board.

Frontend Connector on MicroX Main Board (SBC)

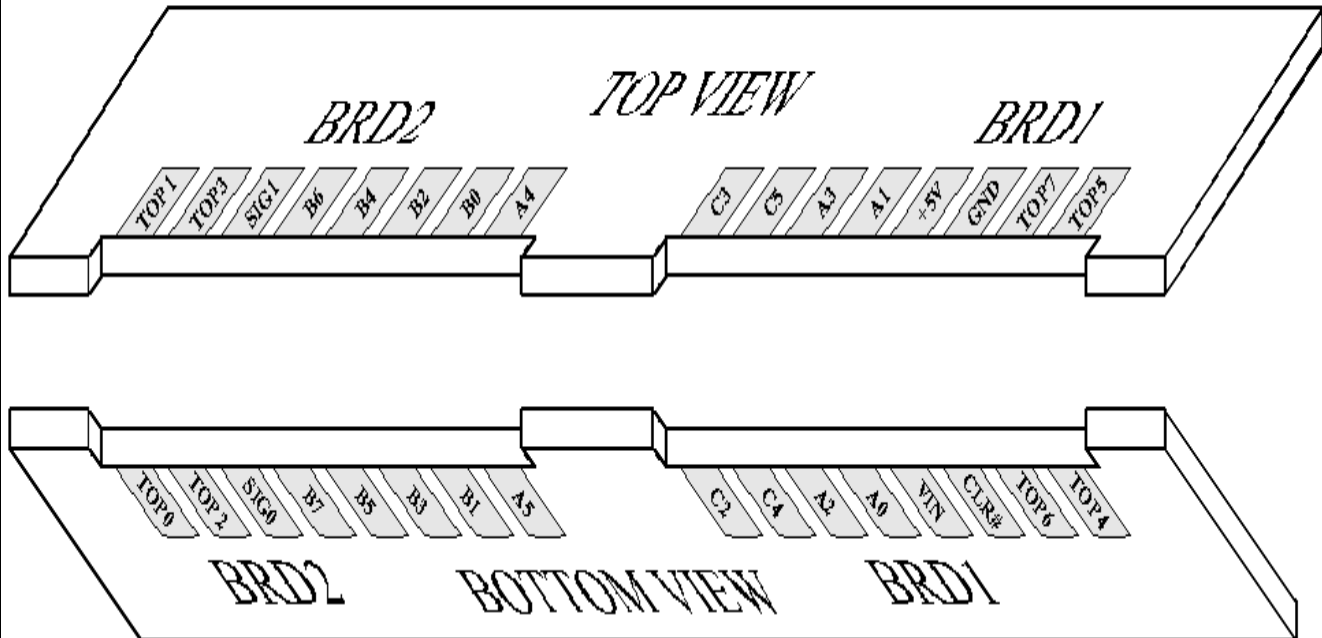
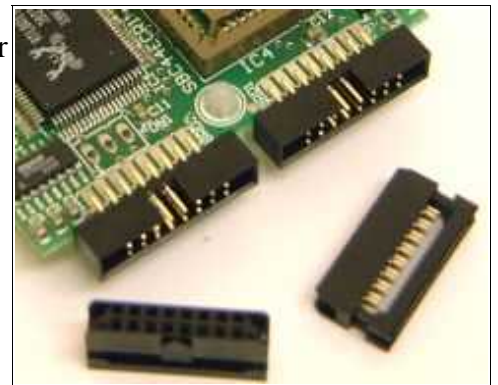

Figure 2

3.3 Connecting IDC connectors to the Frontend Connector

For an easy way of accessing the BRD1 and BRD2 Frontend Connectors signals, 2mm IDC connectors can be soldered onto one or both of the frontend connectors. By doing this, the frontend signals will be available via a standard 2mm ribbon cable. Note that the IDC connectors shown in the image are not soldered onto the Frontend Connector!



3.4 Expansion boards

The SBC28DC's Frontend connectors can be used as an expansion port to add additional functionality. It contains all free CPU port pins, power, I2C, SPI, RS232 signal,..... The image to the right shows the SBC28PC with a Sub-D 9 pin expansion board. For a list of Frontend Boards currently available from Modtronix Engineering, see www.modtronix.com/products/sbc28dc.



Additionally, users can download PCB templates for creating their own Frontend expansion boards from our Downloads page – see www.modtronix.com/downloads.

4 Interfaces

4.1 Micro Match connector with I²C and SPI signals

The SBC28DC has a 6 pin female Micro Match type connector with I²C signals, SPI signals, Vcc and Ground. The PIC can be configured for either I²C or SPI mode, both can not be used at the same time. The Micro Match connector is manufactured by AMP, and is a very small, polarized and cheap connector! This connector is also supported by other manufactures of I²C equipment, which allows devices from different manufactures to be interchanged.

Male Micro Match connectors that fits into this connector are available from various distributors and also from the Modtronix online store. Particularly useful is the “male-on-wire” type connector, seeing that they can be crimped onto a standard 1.27mm ribbon cable. Multiple of these connectors can be daisy chained together to allow several I²C on a single bus. Pre made cables are also available from the Modtronix online store.

The pinouts of the Micro Match I²C connector is:

<i>Micro Match Connector Pin</i>	<i>I²C Signal</i>	<i>SPI Signal</i>
1	SDA - I ² C data I/O (PIC port pin RC4)	SDI - SPI data in (PIC port pin RC4)
2	+5V	+5V
3	Ground	Ground
4	SCL - I ² C clock (PIC port pin RC3)	SCK - SPI clock (PIC port pin RC3)
5	RC5 - Can be used as general purpose pin	SDO - SPI data out (PIC port pin RC5)
6	No Connection	No Connection

For further info on the pinouts have a look at the picture in the *Dimensions* section later on in this document.

For more info on the Micro Match I²C connector see www.modtronix.com/info/i2c/micromatch

4.2 RS232

The SBC28DC contains an industrial quality RS232 interface with transmit, receive, RTS, CTS and power signals. The signals are available on a 9 pin D-Sub, male connector.

Pin 9 can be configured via jumper J2 to be connected to the unregulated supply voltage. This can be used to obtain power for this board. When used, no power has to be supplied via the 2.1mm power connector. It will obtain it's power via the D-Sub connector. Pin 9 is usually assigned to the Ring Indicator (RI) signal. The RI signal is however not used very often any more.

When connecting this board to a computer, or any other device with a standard 9 pin, D-Sub connector that might have the RI signal present, **ensure that jumper J2 is not made!** If jumper J2 is made, the unregulated supply voltage will be put on pin 9 (RI signal), and this will conflict with the RI signal on the device connected to the SBC28DC!

The pinouts (except for pin nine with J2 jumper is inserted) comply to a standard DTE device.

<i>D-Sub Connector</i>	<i>Description</i>
1	No connection
2	RS232 receive - input
3	RS232 transmit - output
4	No connection
5	Signal Ground
6	No connection
7	Request To Send (RTS) – output. Indicates that we want to transmit something.
8	Clear To Send (CTS) – input. Indicates that we can transmit.
9	Vin supply signal

5 Configuration

The SBC28DC board can be configured via jumper J2. Refer to the PCB layout later on in this document for the location of these jumpers and headers.

5.1 Power via D-Sub connector

Pin 9 of the 9 pin, D-Sub connector can be configured via jumper J2 to be connected to the unregulated supply voltage. This can be used to obtain power for this board. When used, no power has to be supplied via the 2.1mm power connector. It will obtain it's power via the D-Sub connector.

When connecting this board to a computer, or any other device with a standard 9 pin, D-Sub connector that might have the RI signal present, **ensure that jumper J2 is not made!** If jumper J2 is made, the unregulated supply voltage will be put on pin 9 (RI signal), and this will conflict with the RI signal on the device connected to the SBC28DC!

6 Specifications

6.1 Absolute Maximum Ratings

<i>Item</i>	<i>Symbol</i>	<i>Min</i>	<i>Typ</i>	<i>Max</i>	<i>Unit</i>
Operating Temperature:	Top	-40		85	°C

6.2 Electrical Characteristics

<i>Item</i>	<i>Symbol</i>	<i>Condition</i>	<i>Min</i>	<i>Typ</i>	<i>Max</i>	<i>Unit</i>
DC Supply Voltage:	Vdd	-	7		35	V
Typical Operating Current with PIC16F876A at 20MHz	Idd	Vdd = 12V		16		mA

6.3 D.C. Characteristics of user I/O pins on Daughter Board connector.

The following values are for common PIC chips like the PIC16F876A or the PIC18F252.

<i>Item</i>	<i>Symbol</i>	<i>Condition</i>	<i>Min</i>	<i>Typ</i>	<i>Max</i>	<i>Unit</i>
Input Low Voltage - configured as TTL input:	V _{IL}		0		0.75	V
Input Low Voltage - configured as Schmitt Trigger input:	V _{IL}		0		1	V
Input High Voltage - configured as TTL input:	V _{IH}		2.05		5	V
Input High Voltage - configured as Schmitt Trigger input:	V _{IH}		4		5	V
Output High Voltage:	V _{OL}	I _{OL} = 8.5mA			0.6	V
Output Low Voltage:	V _{OH}	I _{OH} = 3mA	4.3			V
Capacitive loading:	C _{IO}			50		pF

Many inputs on the PIC are Schmitt Trigger inputs, consult the data sheet for details.

7 Dimensions

The SBC28DC conforms to the MicroX Compact Main Board Dimensions, as shown in Figure 3.

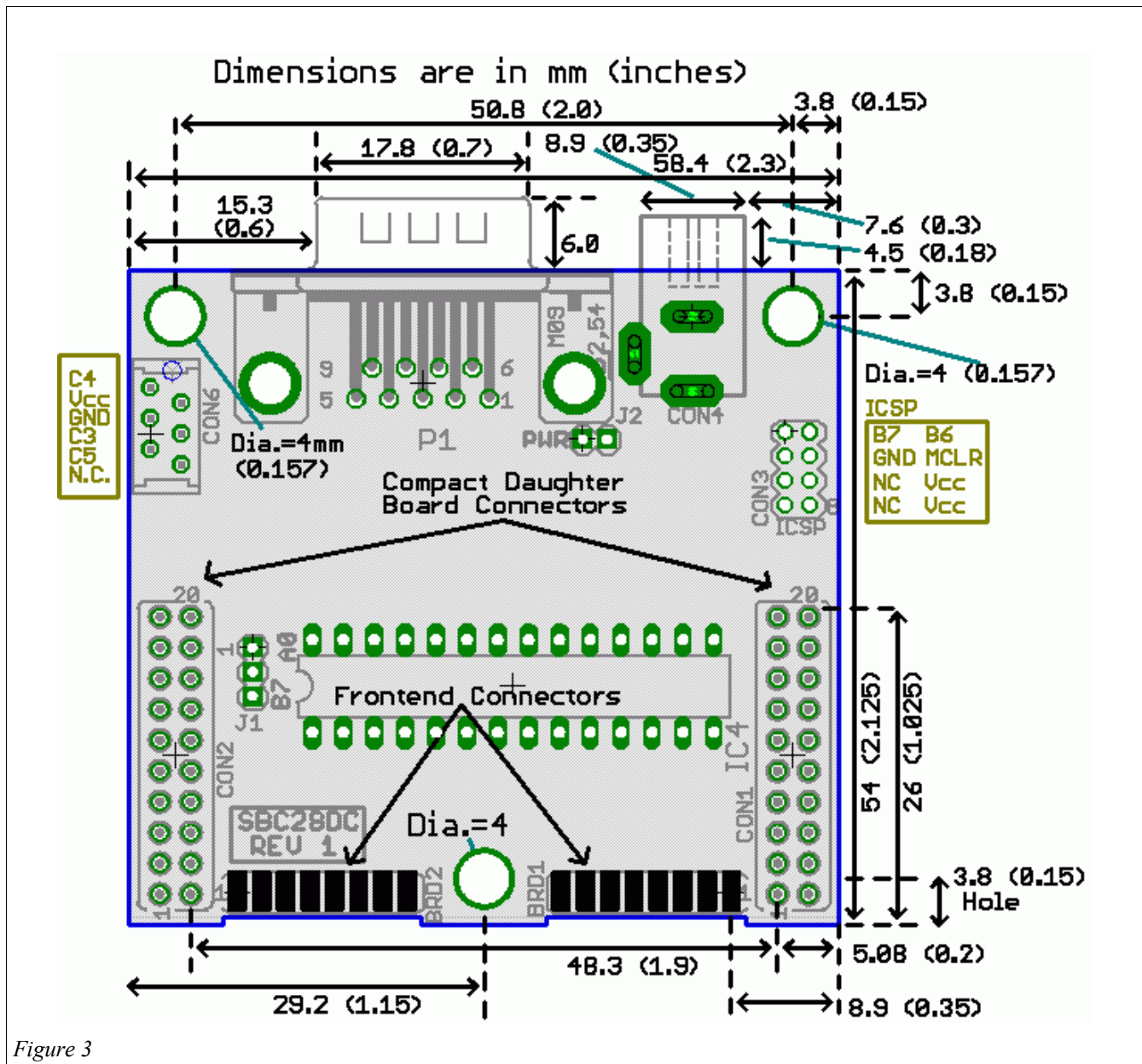

Daughter Board Connector

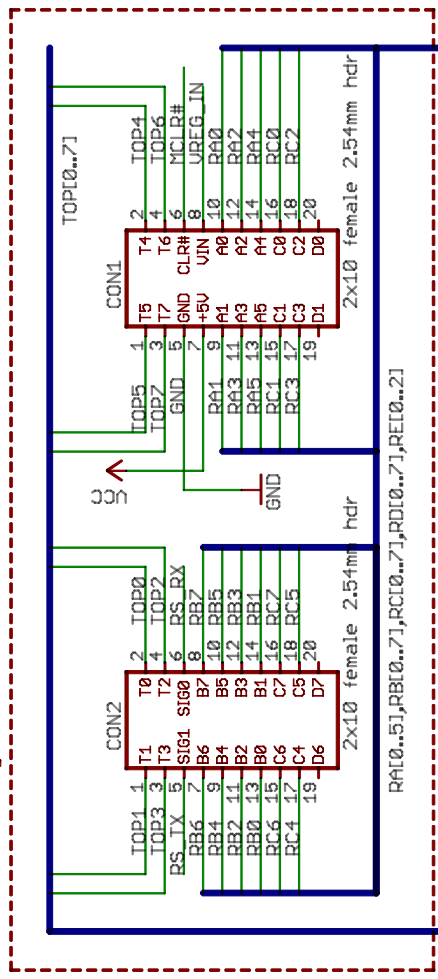

Frontend Board Connector

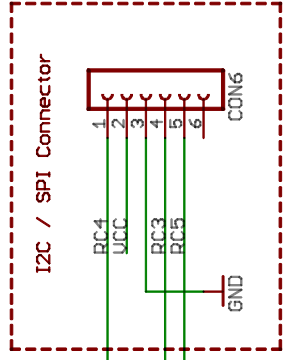
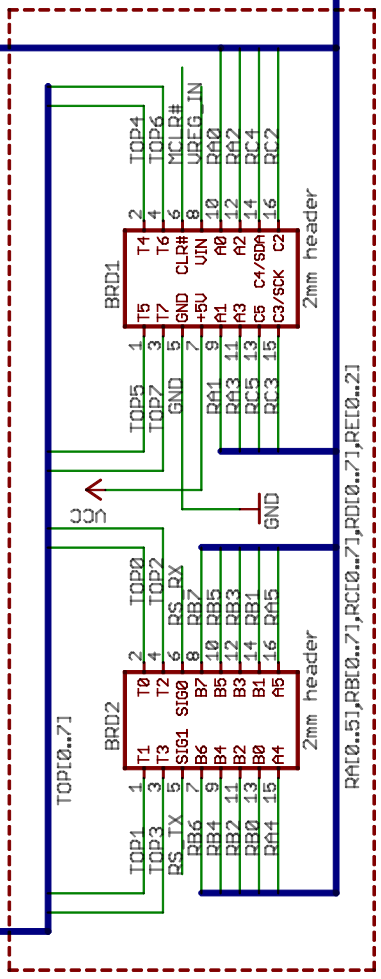

SBC28DC - Modtronix Engineering

TITLE: sbc28dcr1_doc

Document Number:
www.modtronix.com/products/sbc28dc

REV:
1

Date: 8/31/2006 02:43:08p

Sheet: 2/3