



in485P

RS-485 Slave Module with Press-Fit Connectors

----- Part of Modtronix *Presto iMod* product range -----

1 Description

The in485P is an electronic module with a RS-485 interface, and press-fit connectors. It enables 3.3V devices (like a Microcontroller for example) to communicate with nodes on a RS-485 network. It uses a 1/8 load transceiver chip, enabling 256 nodes on a single bus.

It uses the 3.3V Sipex SP3078E RS-485/RS-422 Transceiver chip, which has a 1/8 Load and Failsafe operation. For details on the SP3078E, download it's datasheet from www.exar.com

The in485P is part of the Modtronix *Presto iMod* product range.

Picture 1: in485P Board With Terminal Block Plug

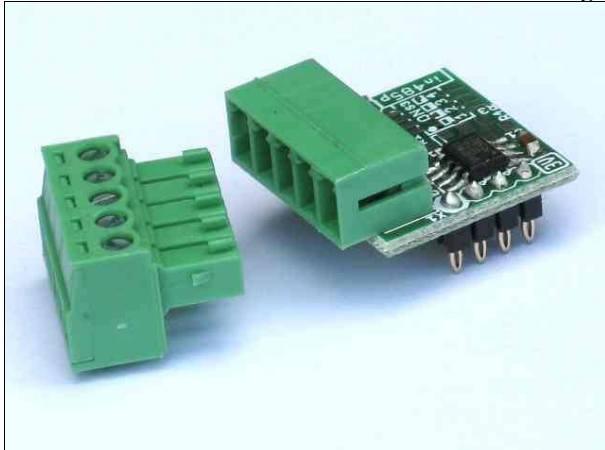

Picture 2: in485P Board as seen from the top

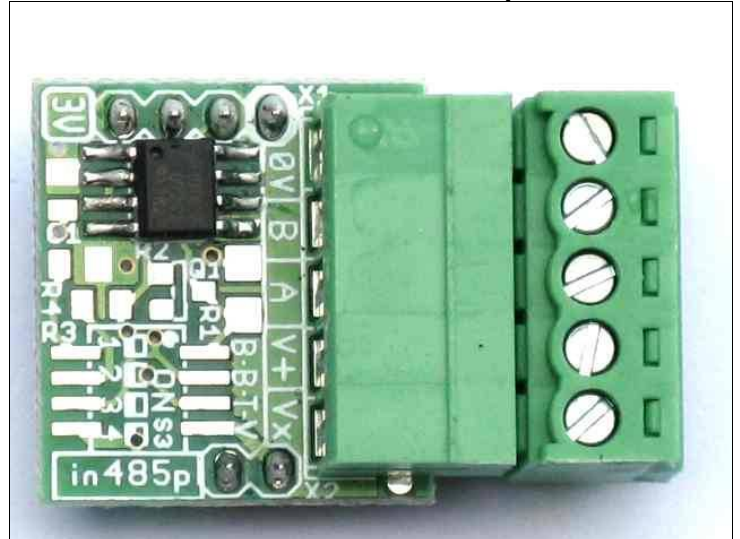

2 Features

- Is part of our *Presto iMod* product range, can be used together with other Presto products. For details, see www.modtronix.com/products/presto
- High quality assembly, with brand name, quality components. No cheap, “no name brand” components are used!
- Press-Fit connectors are gold plated for excellent contact. Can be mounted on PCB with 1mm holes (like Vero Board).
- Wide Operating Range: 3.3V at -40°C to +85°C
- ±15kV ESD protection for RS485 pins
- Advanced receiver-failsafe protection for open, shorted or terminated lines
- Up to 256 Transceivers may share bus (1/8 Unit Load)
- Very low load for 8x greater fan-out
- Hot Swap glitch protection RE and DE
- Thermal shutdown protects against driver contention

3 Connectors

3.1 Press-Fit Connector

The in485P has two rows of press-fit connectors. They can be pressed into 1.00mm holes on a 1.6mm thick (standard PCB thickness) target board. A standard Veroboard (prototype board) has 1.00mm holes, and is an example of a board that can be used. No special tool is required, and they can be inserted by applying firm pressure to the connectors. Once fitted to the target board, the board is very secure, and can not be removed by hand any more. A screwdriver or similar tool can be used to remove the board if required.

If the in485P is to be soldered onto the target board, 1.10mm holes can be used. This will allow it to be inserted much easier than with 1.00mm holes. When using 1.10mm holes, the board can be removed by hand.

Table 2 shows the pin-outs of the X1 and X2 connectors (iMod left and right connectors). For the location of these connectors and pin-outs, see [6 Dimensions](#).

Table 1: Press-Fit Connector

<i>Left Press-Fit Connector (X1)</i>			<i>Right Press-Fit Connector (X2)</i>		
<i>Pin</i>	<i>Signal</i>	<i>Description</i>	<i>Pin</i>	<i>Signal</i>	<i>Description</i>
1	Gnd	0V Supply Voltage	1	Vaux	Auxiliary Voltage. Can be used to make the Auxiliary voltage obtained via the Press-Fit connector available on the Terminal Block connector (by making J1 solder jumper on bottom of board).
2	CS	Transmit Enable. When 0, receive mode is enabled. When 1, transmit mode is enabled.	2	Vcc	Positive Supply Voltage, has to be 3.3V.
3	RX	Receive, will contain valid data when CS pin is 0.			
4	TX	Transmit, the state of this pin will be transmitted on the bus when CS pin is 1.			

Picture 3 Shows the in485P board fitted to a target board.

Picture 3: in485P Board inserted on target board

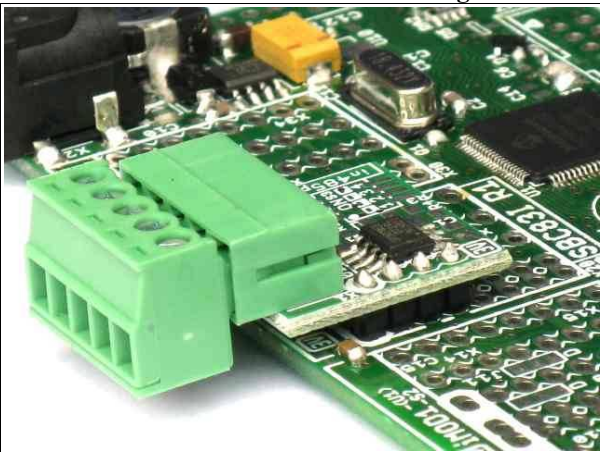

3.2 Terminal Block Connector

The in485P has a 5 pin, 3.5mm Terminal Block connector. For the location and pin numbering of this connector, see [6 Dimensions](#).

Note that pin 1 **is not** connected to the Vaux signal on the press-fit connector by default. Solder jumper J1 (on the bottom of the board) has to be made to make this connection.

Table 2: Terminal Block Connector

Connector Pin	Description
1	Vaux – Marked as Vx on board. Auxiliary Voltage obtained via press-fit connector. This pin can be connected to the Vaux pin on the press-fit connectors by making the J1 solder jumper on the bottom of the board. Can be used to access auxiliary voltage of target board that in485P is mounted to.
2	V+ - Positive supply voltage of target board in485P is mounted to, obtained via press-fit connector.
3	A - RS-485/RS-422 Signal A
4	B - RS-485/RS-422 Signal A
5	Gnd - 0V

4 Presto iMod Modules

The in485P is part of the Modtronix *Presto iMod* product range. All iMod boards have two rows of press-fit connectors, a left and a right row. The signals on these connectors are pre-defined, allowing modules to be interchangeable.

A single iMod module is defined to have a maximum row spacing of 0.7", referred to as one module width. Modules can however be wider than one module width, other common module widths are 0.9", 1.1" and 1.6". Target boards can provide iMod Ports for fitting iMod modules. An iMod port is very simple and cheap to implement, and just two rows of 1.00mm holes 0.7" apart. Modules wider than 0.7" will normally take up two iMod Ports on the target board. It is recommended that multiple iMod Ports be spaced 0.2" apart. To help inserting the iMod module correctly into the iMod Port, pin 1 of the left connector is marked (white band around pad) on the iMod Module and iMod Port, and should always be aligned!

Picture 4 shows a target board with two iMod Ports. The left iMod Port is 0.9" wide, which is wider than a standard iMod module. This is so that a 0.9" iMod module can also be fitted to it (like the im28J60 Ethernet Module). Also note that the iMod Ports are spaced 0.2" apart, and that iMod modules wider than one module width can be fitted using both iMod Ports. Provision is also made for possible narrower iMod modules of 0.6" wide.

Picture 4: Target board with two iMod Ports.

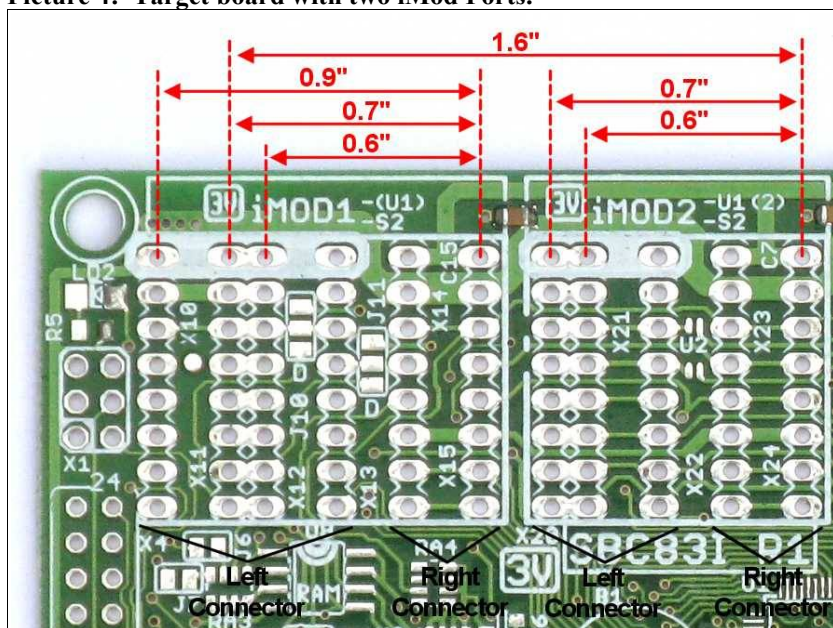

5 Specifications

5.1 Absolute Maximum Ratings

Item	Symbol	Min	Typ	Max	Unit
Operating Temperature	Top	-40		85	°C

5.2 Electrical Characteristics

For more detailed Electrical Characteristics, see SP3078. It can be downloaded from www.exar.com.

Item	Symbol	Condition	Min	Typ	Max	Unit
DC Supply Voltage	Vdd	3.3V	3.0	3.3	3.6	V
Typical Supply Current	Icc		0.8		1.5	mA
Supply Current in Shutdown mode	Ishdn	RE =VCC , DE = GND	0.05		3	uA
Input High Voltage	Vih	DE, DI, RE	2			V
Input Low Voltage	Vil				0.8	V
Driver Short-Circuit Current	Iosd		0		250	mA
Thermal-Shutdown Threshold	Tts			165		°C

6 Dimensions

The in485P Dimensions are shown in Figure 2.

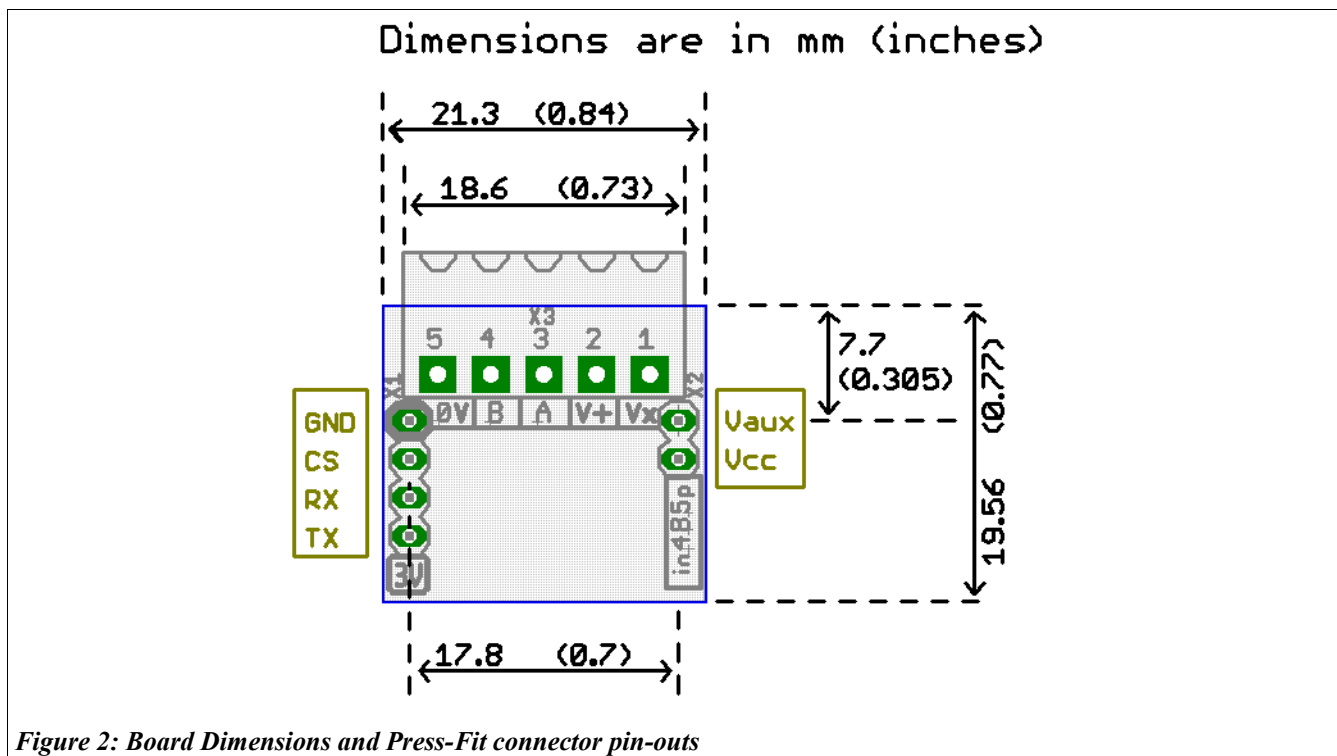

7 Schematics

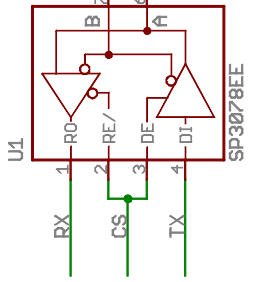
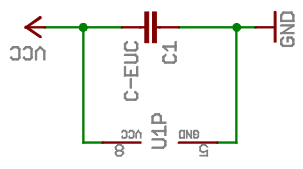
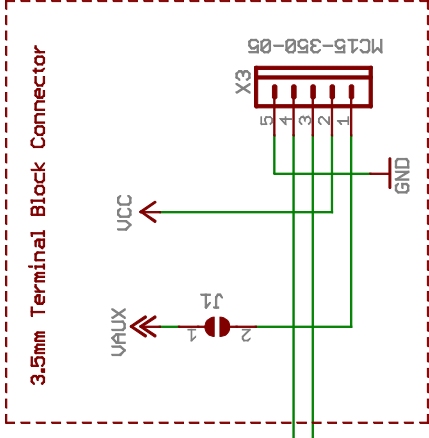
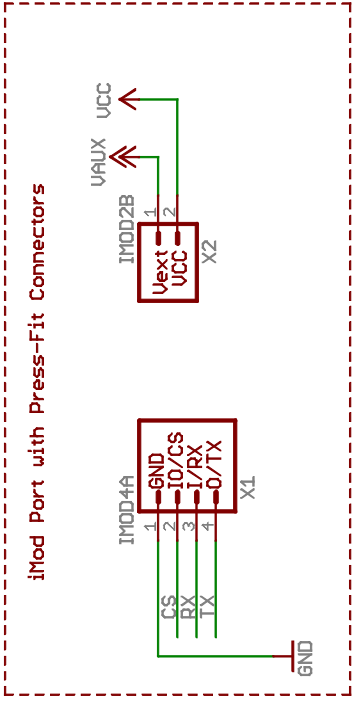

RS485 iMod Interface Module
Modtronix Engineering

TITLE: in485p_doc

Document Number:

REV: 1

Date: 5/27/2008 02:40:08p

Sheet: 1/1