



DEV16T

LCD Daughter board

Table of Contents

1 Introduction.....	2
2 Features.....	3
3 Expansion Connectors.....	4
3.1 Daughter Board Connectors.....	4
4 LCD Display.....	5
5 Input Buttons S1 to S4.....	5
6 Buzzer.....	5
7 Connector J1.....	5
8 Connector J2.....	5
9 Temperature Sensor.....	5
10 Specifications.....	6
10.1 Absolute Maximum Ratings.....	6
10.2 Electrical Characteristics.....	6
11 Dimensions.....	7
12 Schematics.....	8

1 Introduction

The following documentation is for the DEV16T Revision 1, which is marked on the PCB as DEV16T REV1.

DEV16T is a LCD Daughter board that plugs into the daughter board connector of a Modtronix PIC based MicroX SBC board, like the SBC44B for example.

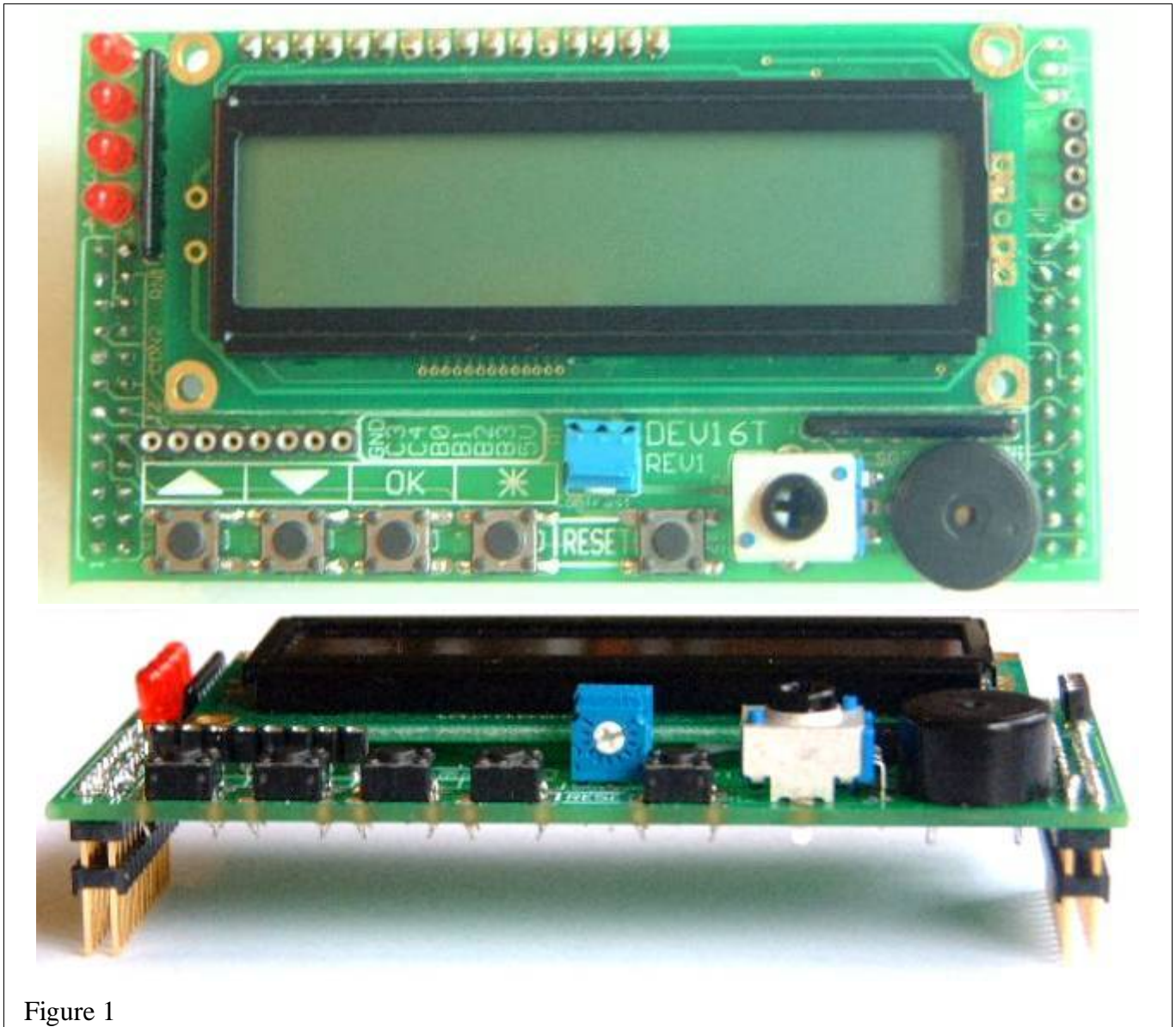

Figure 1

2 Features

- LCD Character Display, 2 x 16 characters. Used in 4 bit mode to save I/O pins.
- 5V Buzzer. Will connect to PWM module on most PIC CPUs.
- Potentiometer for testing PIC ADC.
- Trimmer for setting LCD contrast.
- Four buttons for user input.
- Reset button.
- 4 LEDs for user output.
- Space for mounting low cost TO-92 temperature sensor like National LM19.
- 8 pin Female Pin header (Tulip type) with GND, +5V, B0, B1, B2, B3, C3 and C4 signals. Wires can easily be plugged into it to access the signals.
- 4 pin Female Pin header (Tulip type) with GND, A0, A1 and A3 signals. Wires can easily be plugged into it to access the signals. These PIC ports also usually have Analog input capability on most PIC CPUs.
- Has two 2x12 pin, 2.54mm (standard grid) pin headers that plugs into the Daughter board connector of any Modtronix PIC based MicroX SBC boards (Not compact SBC board).
- Two 2x12 pin headers are 1.4" apart, and can be plugged into breadboard for prototyping.

3 Expansion Connectors

3.1 Daughter Board Connectors

The DEV16T's Daughter Board connectors have connections to all devices on the board. It conforms to Modtronix's MicroX Daughter Board connector format, and can thus be plugged into the Daughter board connector of any Modtronix MicroX SBC board (Not compact SBC board). When plugged into a SBC boards Daughter Board connector, the port pins (except T0 to T7) will be connected to corresponding PIC port pins. For example, when plugged into the SBC44B SBC's Daughter Board connector, B0 will be connected to the PIC RB0 port, C0 will be connected to PIC RC0 port.....

The connectors pins are mapped to the following signals:

<i>CON2 and CON3 Connector</i>		<i>CON1 Connector</i>	
<i>Daughter Board Port Pin</i>	<i>Signal</i>	<i>Daughter Board Port Pin</i>	<i>Signal</i>
T0	N.C.	T4	N.C.
T1	N.C.	T5	N.C.
T2	N.C.	T6	N.C.
T3	N.C.	T7	N.C.
SIG0	N.C.	GND	GND
SIG1	N.C.	+5V	+5V
B0	Pin 4 on J2 connector	VIN	N.C.
B1	Pin 5 on J2 connector	CLR#	Reset button
B2	Pin 6 on J2 connector	A0	Pin 2 on J1 connector
B3	Pin 7 on J2 connector	A1	Pin 3 on J1 connector
B4	Button S3	A2	Input from Potentiometer R2
B5	Button S4	A3	Pin 4 on J1 connector
B6	N.C.	A4	Input from Temperature Sensor (If assembled)
B7	N.C.	A5	N.C.
C4	Pin 3 on J2 connector	C0	Button S1
C5	N.C.	C1	Button S2
C6	N.C.	C2	Buzzer
C7	N.C.	C3	Pin 2 on J2 connector
D2	DB6 of LCD Display	D0	DB4 of LCD Display
D3	DB7 or LCD Display	D1	DB5 of LCD Display
D4	LED1	E0	RS or LCD Display
D5	LED2	E1	R/W or LCD Display
D6	LED3	E2	E or LCD Display
D7	LED4	GND	GND

4 LCD Display

The LCD display has a standard controller chip that can be used in 8 or 4 bit mode. To save I/O lines, it is used in 4 bit mode – only DB4 to DB7 is required. Trimmer resistor R1 can be adjusted to set the contrast of the LCD display. The LCD displays datasheet can be downloaded from the DEV16T product page.

5 Input Buttons S1 to S4

When this board is connected to the Daughter Board connector of a Modtronix PIC based SBC board like the SBC44B, buttons S1 to S4 will be connected to PIC port pins RC0, RC1, RB4 and RB5. On board pull-up resistors are provided for switches S1 and S2. The PIC port B pull-ups have to be enabled to provide pull-up resistors for switches S3 and S4. There is no hardware debounce circuitry, seeing that this can easily be implemented in software.

6 Buzzer

A external drive buzzer is connected to port pin C2. When this board is connected to the Daughter Board connector of a Modtronix PIC based SBC board like the SBC44B, the buzzer will be connected to PIC port pins RC2. On most PICs, RC2 can be configured as a PWM output, thus allowing the buzzer frequency to be adjusted.

7 Connector J1

Connector J1 is a 4 pin, 2.54mm tulip type female pin header. Wires can easily be plugged into it to access the signals. When this board is plugged into the Daughter Board connector of a Modtronix PIC based SBC board like the SBC44B, connector J1 will be connected to PIC port pins RA0, RA1 and RA3. Ports A0 and A1 are connected through a 1k resistor for protection. The port A0 and A1 resistors (RN2A and RN2B) can be bypassed by solder jumpers marked 'A1' and 'A2' on the back of the board.

8 Connector J2

Connector J2 is a 8 pin, 2.54mm tulip type female pin header. Wires can easily be plugged into it to access the signals. When this board is plugged into the Daughter Board connector of a Modtronix PIC based SBC board like the SBC44B, connector J2 will be connected to PIC port pins RB0, RB1, RB2, RB3, RC3 and RC4.

9 Temperature Sensor

Space is provided for a TO-92 temperature sensor (like National LM19) to be assembled. When assembled, the sensor's output will be connected to port A4, which is normally a Analog Input on most PICs. By reading the analog value of the temperature sensor, the current temperature can be calculated.

10 Specifications

10.1 Absolute Maximum Ratings

<i>Item</i>	<i>Symbol</i>	<i>Min</i>	<i>Typ</i>	<i>Max</i>	<i>Unit</i>
Operating Temperature:	Top	0		50	°C
Storage Temperature:	Tst	-10		60	°C

10.2 Electrical Characteristics

<i>Item</i>	<i>Symbol</i>	<i>Condition</i>	<i>Min</i>	<i>Typ</i>	<i>Max</i>	<i>Unit</i>
DC Supply Voltage:	Vdd	-	2.7		5.5	V
Typical Operating Current	Idd	Vdd = 5V		2.7		mA

11 Dimensions

The DEV16T conforms the MicroX Compact Main Board Dimensions, as shown in Figure 2.

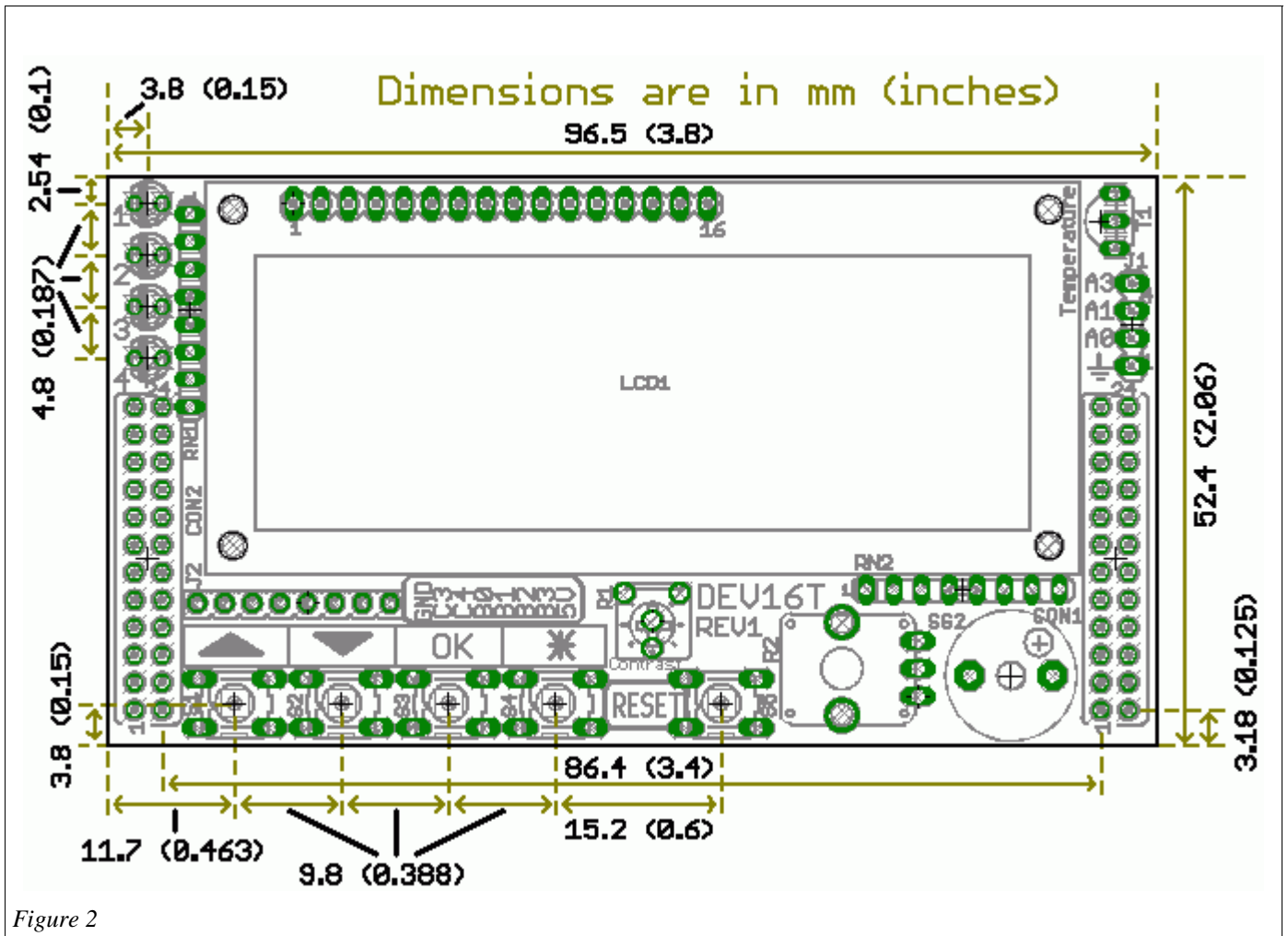

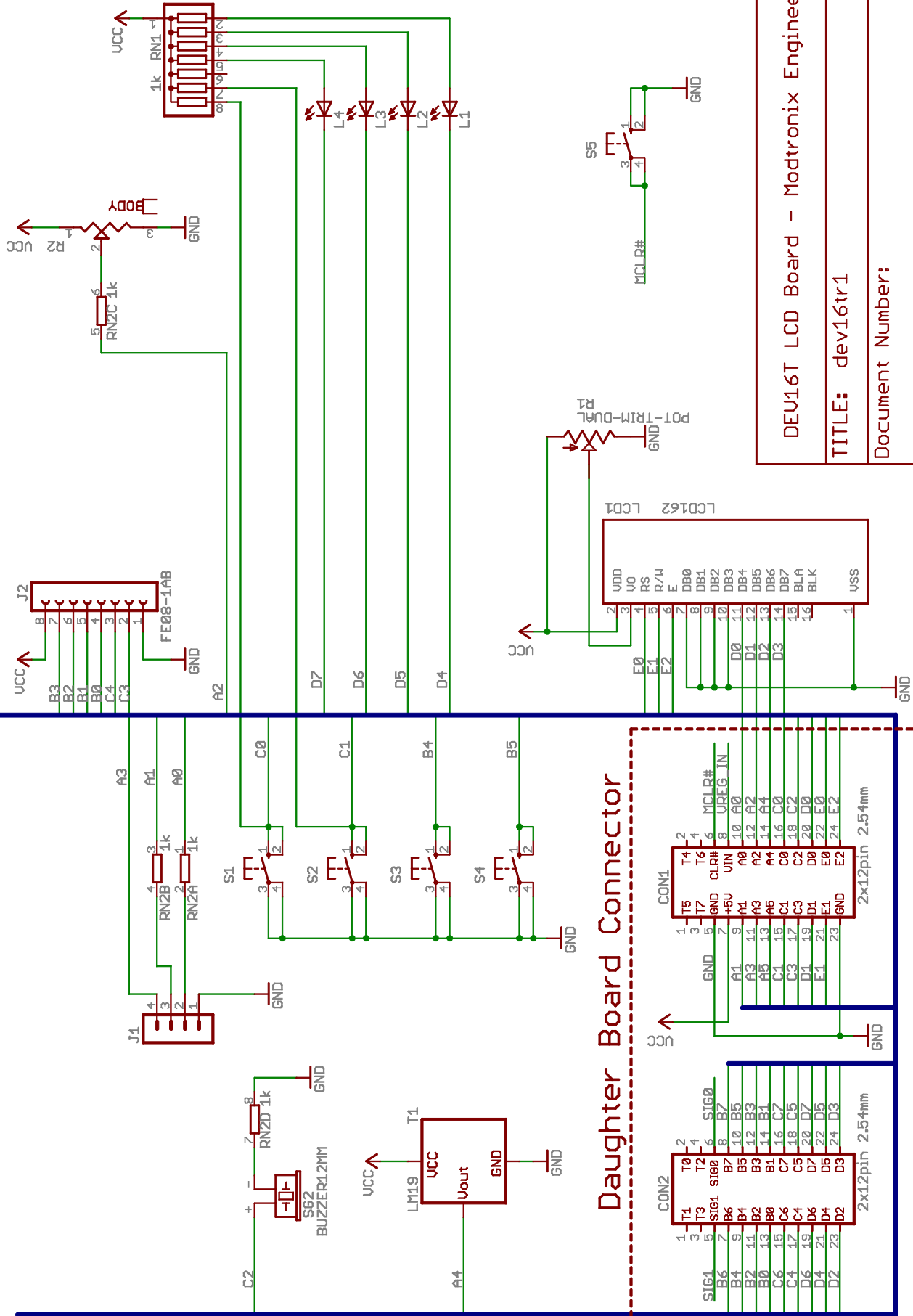

Daughter Board Connector

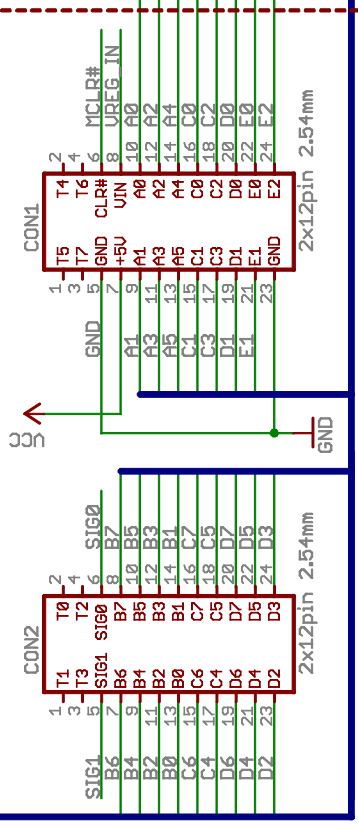

DEU16T LCD Board - Modtronix Engineering

TITLE: dev16tr1

Document Number:

REV:

Date: 12/16/2004 09:27:56a

Sheet: 1/1